

CERRO ORTIGA II

Pluma Inc.

Claire Bradford

Hailey Goupille

Ruth Oppliger



OUTLINE

- Pluma Inc. background
- Problem description
- Gravity-fed water system background
- Community background
- Final design
- Cost estimate
- Construction schedule
- Conclusion
- Questions



MISSION STATEMENT

To design a water distribution system to meet the needs of the Cerro Ortiga II community members and provide knowledge of engineering water systems to assist the community in implementing the project.

Pluma Inc. designs for the sustainable, economical, social, and the health and safety needs of the Cerro Ortiga II community.



PLUMA INC.

PROBLEM DESCRIPTION

- Design gravity-fed water system
- Provide clean water for:
 - 78 people
 - 13 homes
- Redesign previous infrastructure
- Maximum budget: \$8,000



GRAVITY FED WATER SYSTEM

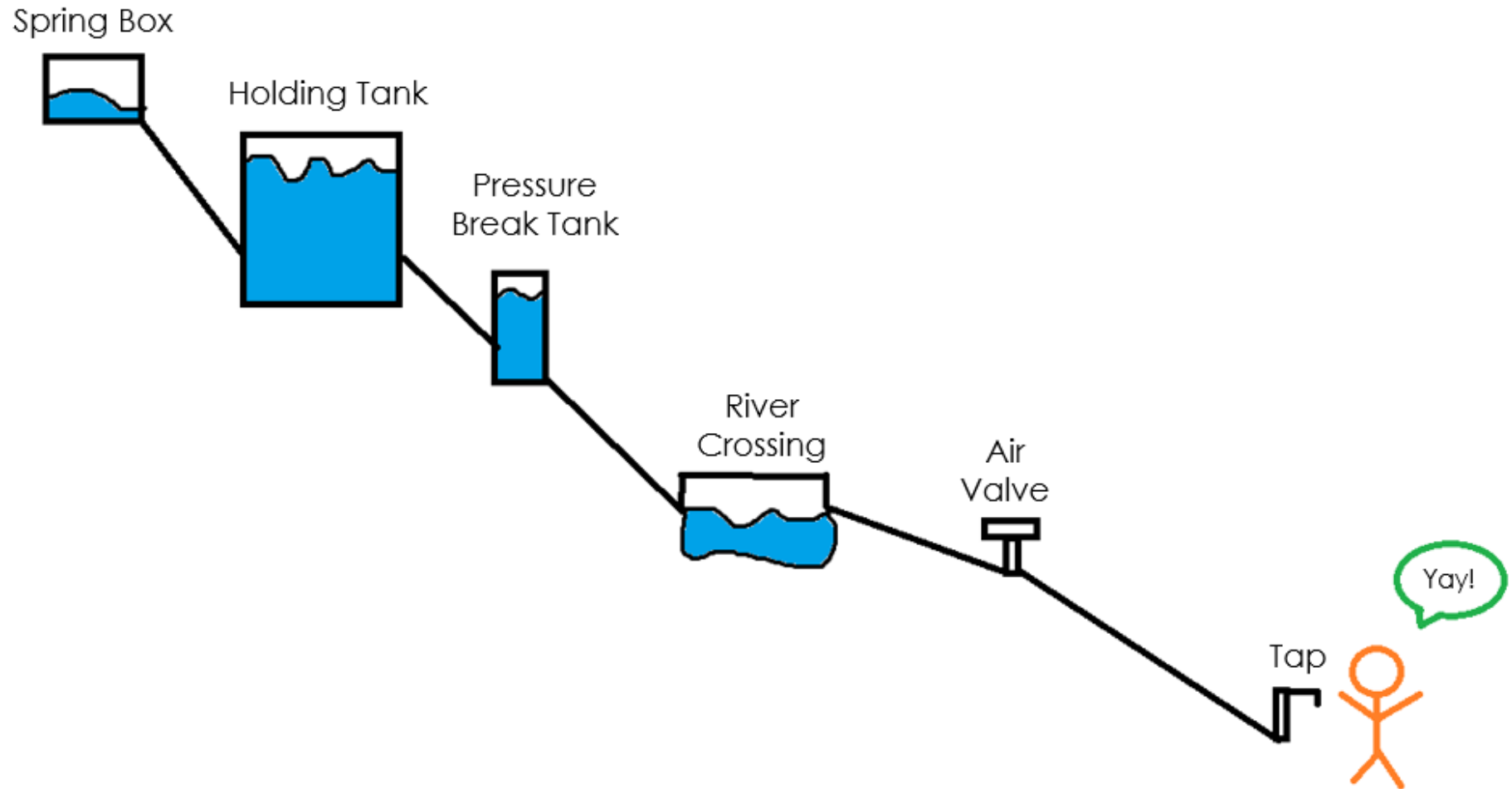

COMMUNITY BACKGROUND

- Ngöbe-Buglé Comarca
- Population Size: 600 citizens
- Area: 15-20 mi²
- Terrain
 - Steep Hills
 - Trail Condition
 - Heavy Rain
- Remote Location

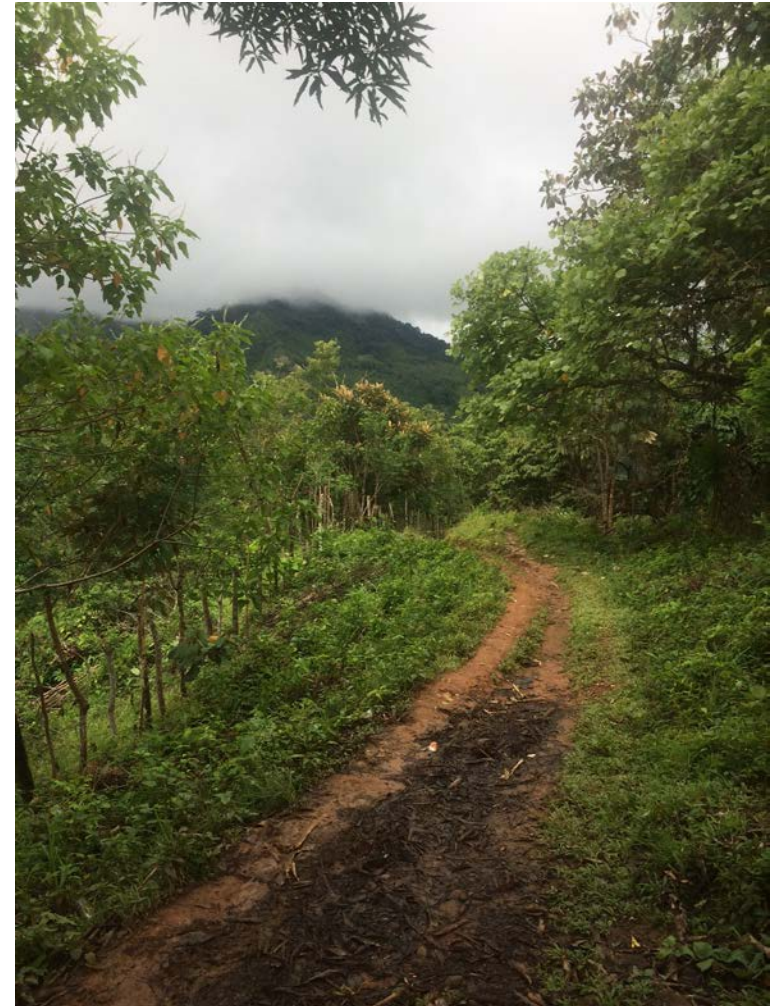

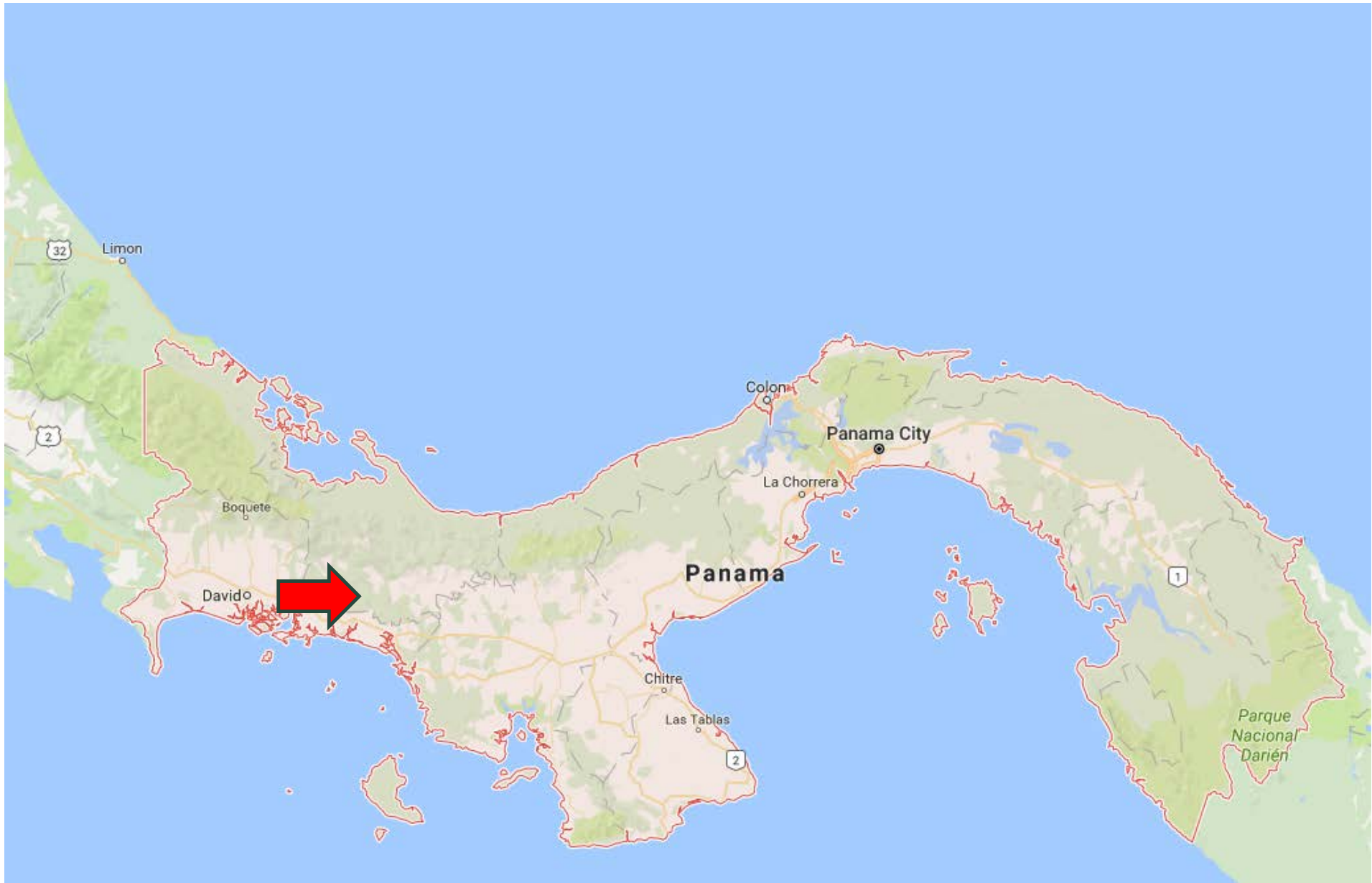

EDUCATION

- Points System
- Cost of Attendance: \$5/year
- Classroom Environment
- On Site: K-9th
- Off Site: 10th-12th
- Monday-Thursday: 8am-12pm



WORK LIFE

- Subsistence agriculture
 - Corn, cacao, yucca, plantains, coffee, bananas, rice
- Hand-made items
- Stores on site
- Salary jobs



TRADITION AND COMMUNITY LIFE

- Men and Women are equal
- Child-bearing begins at a young age
- Unions vs. Marriage
- Heavily hunted area
- No running water
- House Structure
 - Thatched roof
 - Dirt floors



GOVERNMENT AID

- \$120/month per family
- \$80/year for school supplies
- Free health clinic
 - Every 3 months
 - Dental, check-ups, testing, vaccinations
- Ministry of Health (MINSA)
 - Previous water system



CHALLENGES

- Lack of structure and maintenance on water system
- Limited access to materials
- High cost for community
- Lack of knowledge of water system
- Interference from community members
- Community lacks a sense of ownership



SURVEY TECHNIQUES



WATER QUALITY

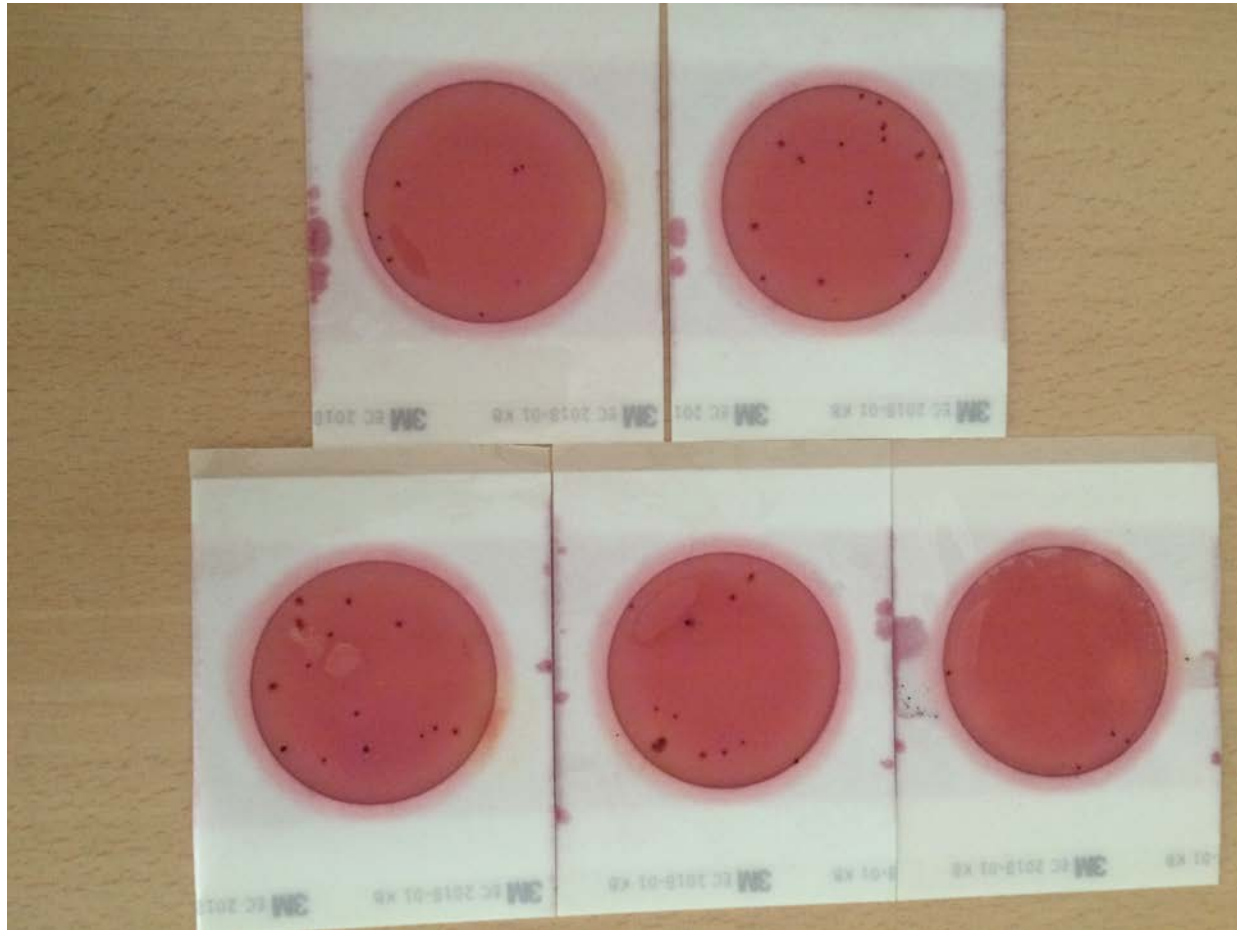

Quality Test	Number of Coliforms
1	19
2	9
3	4
4	12
5	14
Avg.	11.6

FLOW RATE AND DEMAND

- Source: Ground spring
- Flow Rate: 1.13gpm
- Total: 1,600 gallons/day
- Allowable water usage: 20 gallons/person/day
- World Health Organization
 - Minimum of 5 gallons/person/day for Basic Water Access



OLD SYSTEM

Spring Box



Holding Tank



Chlorinator



Final Design



SYSTEM OUTLINE

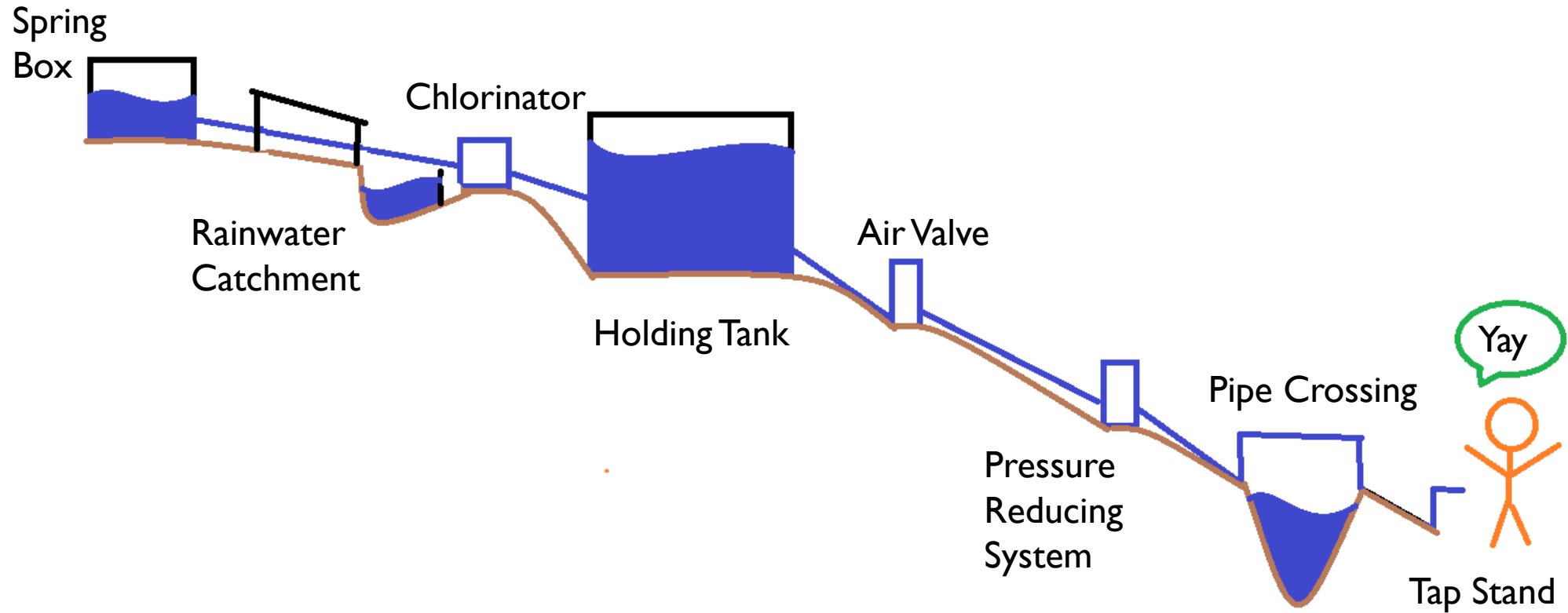

SPRING BOX

Old Infrastructure



New Design

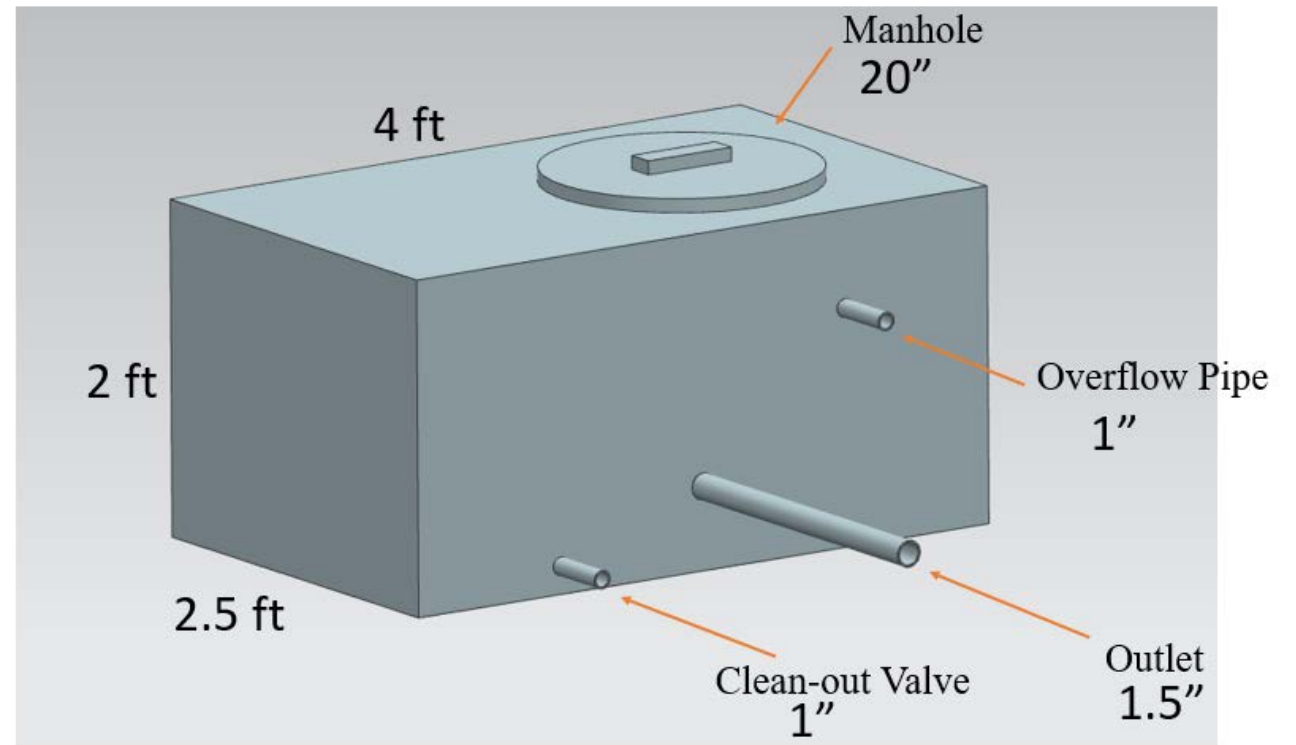

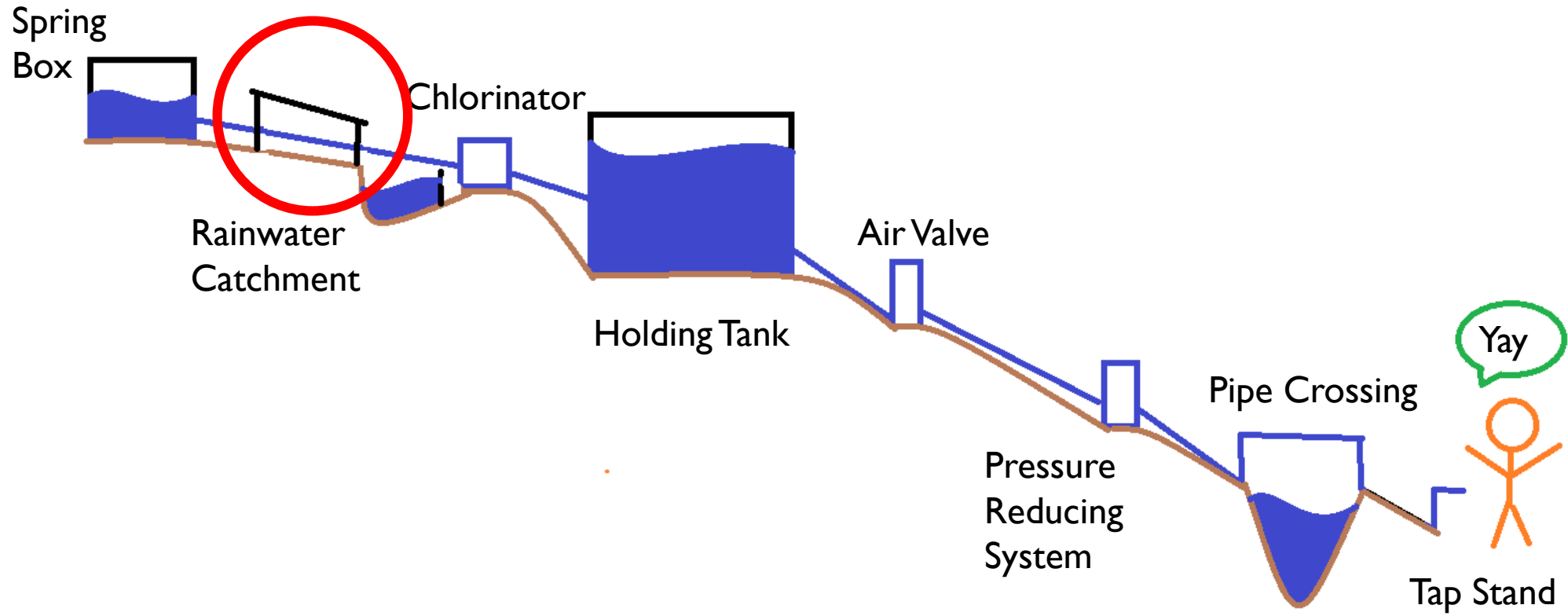

RAINWATER CATCHMENT

- System for laundry area
- Area will be dammed
- Roof area: 25 ft²
- Captures an average of 170 gallons/month
- Materials:
 - Corrugated PVC
 - 4 x 4 Wooden Posts



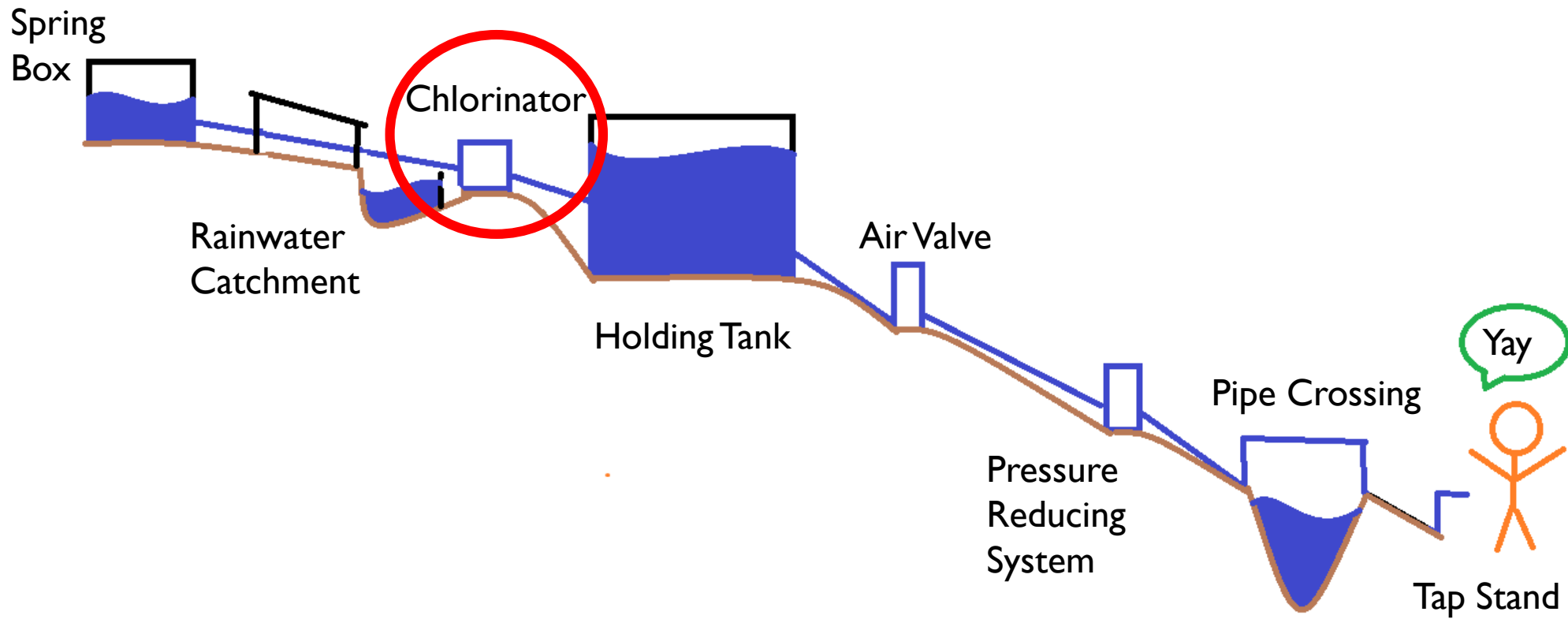

CHLORINATOR

- Recommend: Insert 3 tablets every 1-2 weeks
- Tablets:
 - 200 grams
 - 3 inch in diameter
 - 70-90% available free chlorine
- Tablet dissolution rate: 5-7 days
 - Study flowrate: 1.2 gpm
 - Cerro Ortiga flowrate: 1.13 gpm
- Cost: \$25
 - 15 tablets/visit

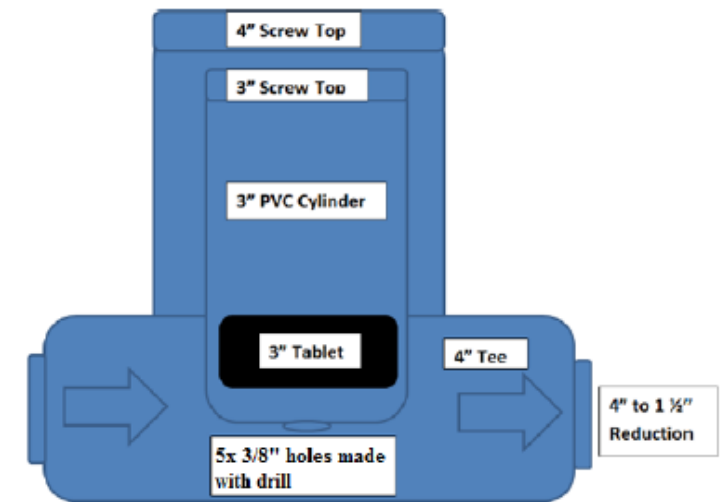

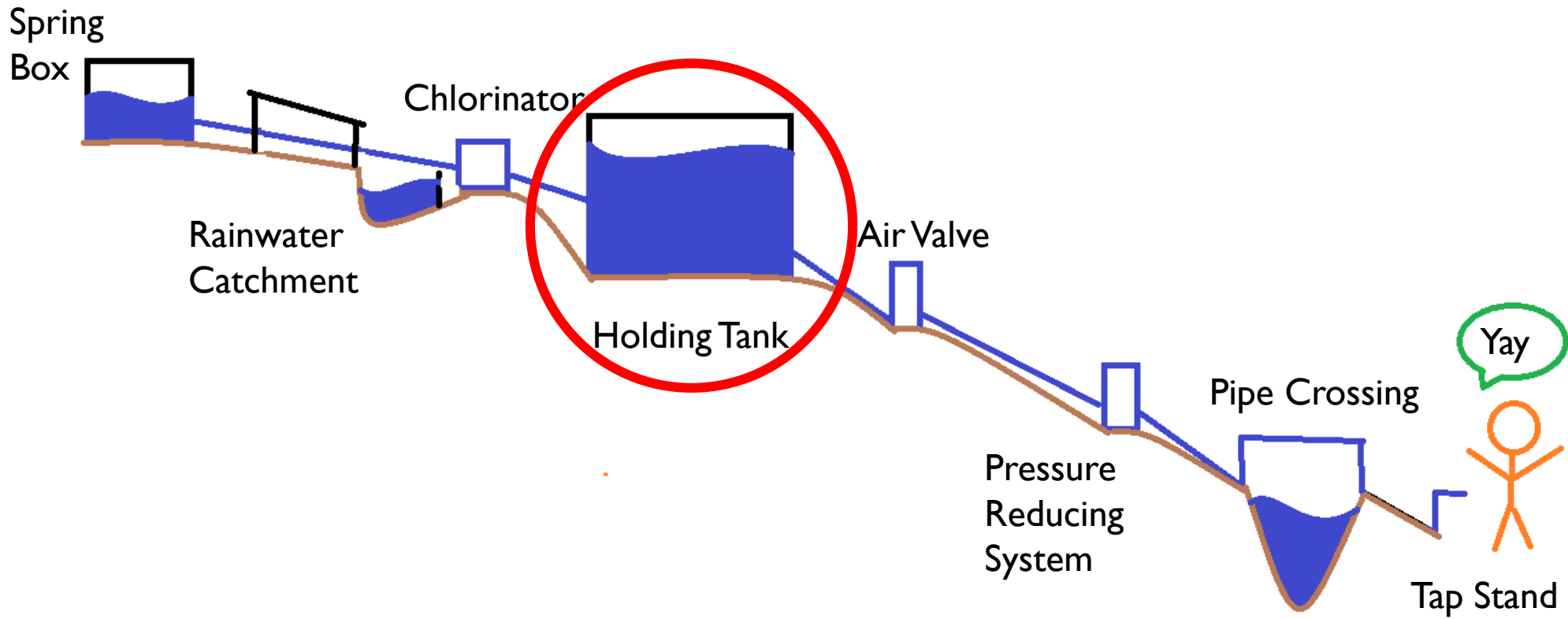

HOLDING TANK

Old Infrastructure

- 4,500 gallon



New Design

- 2,000 gallons

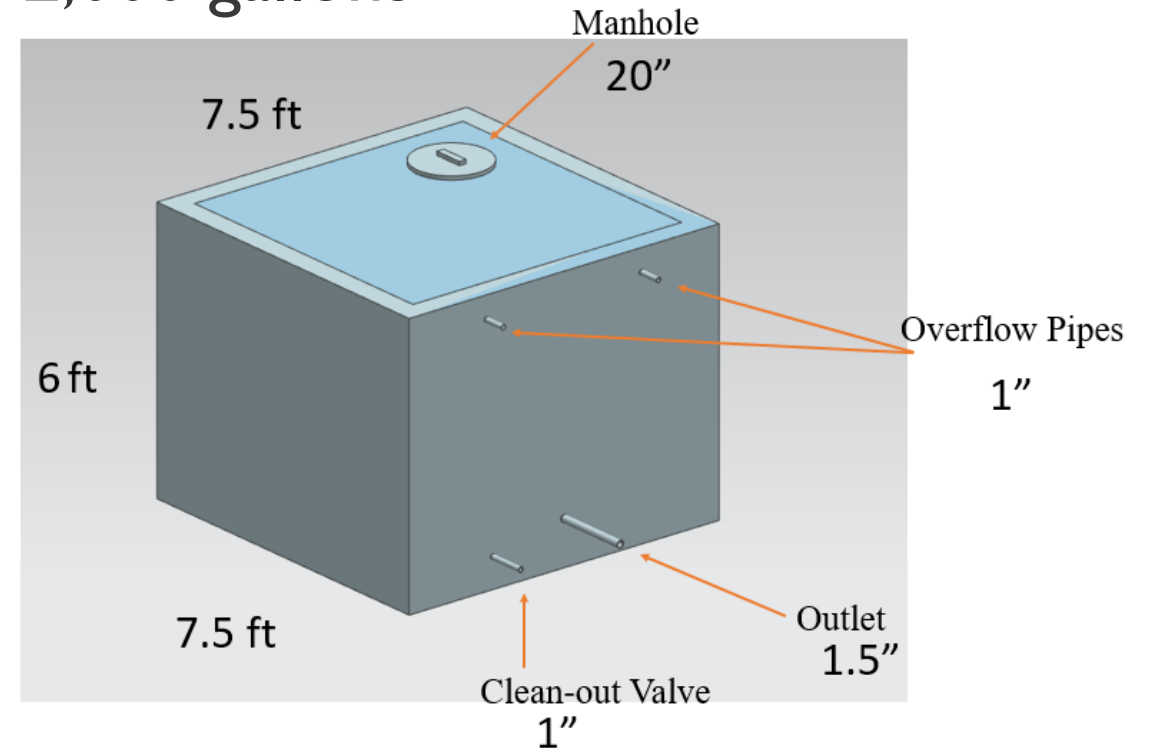

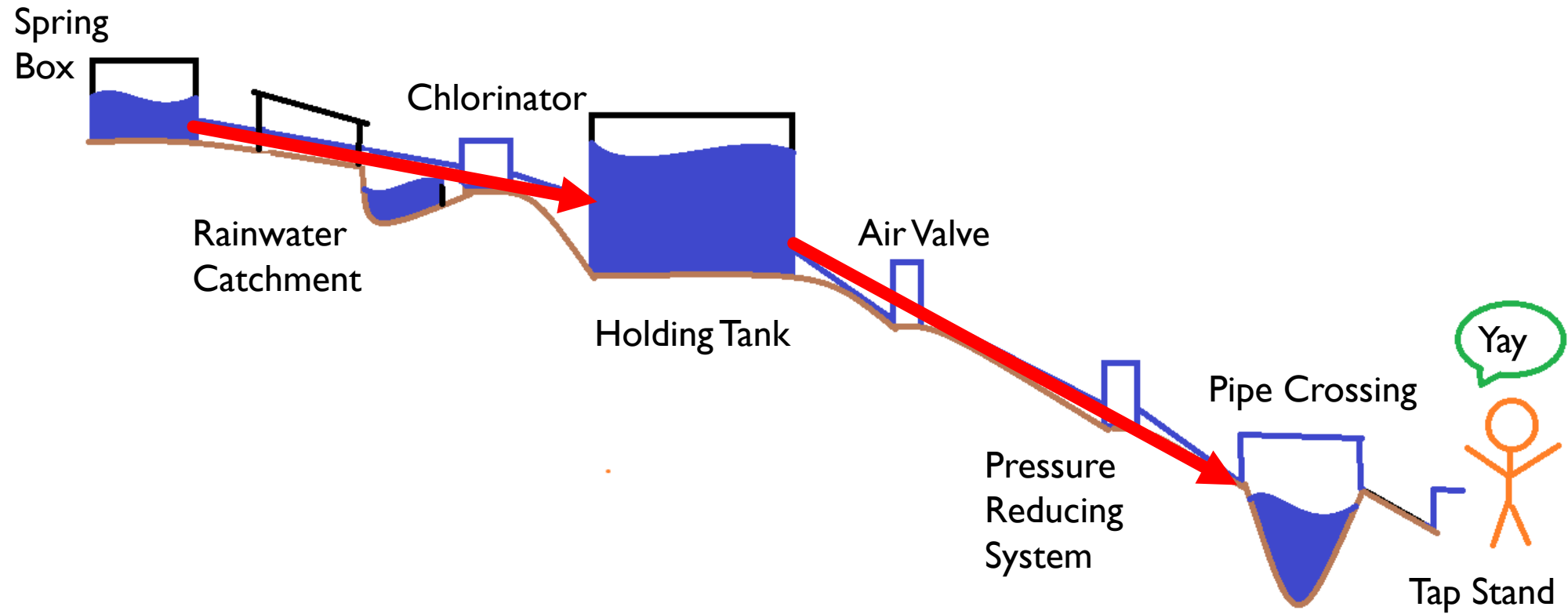

PIPELINE

- Total Pipeline: 8,180 ft (1.5 miles)
- Main Line: 2,500 ft
- Pipe Diameter
 - 1.5 inch on main line
 - 1 inch on branches
- Pipe material is SDR 26

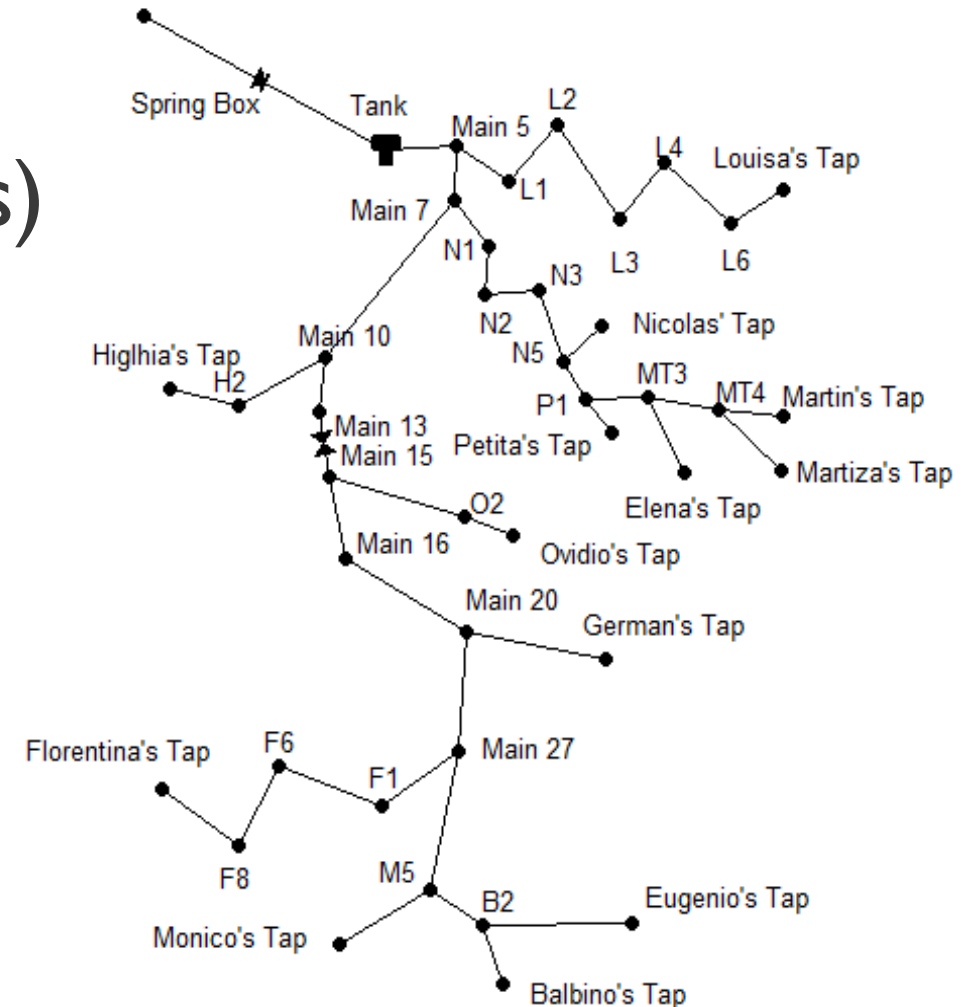

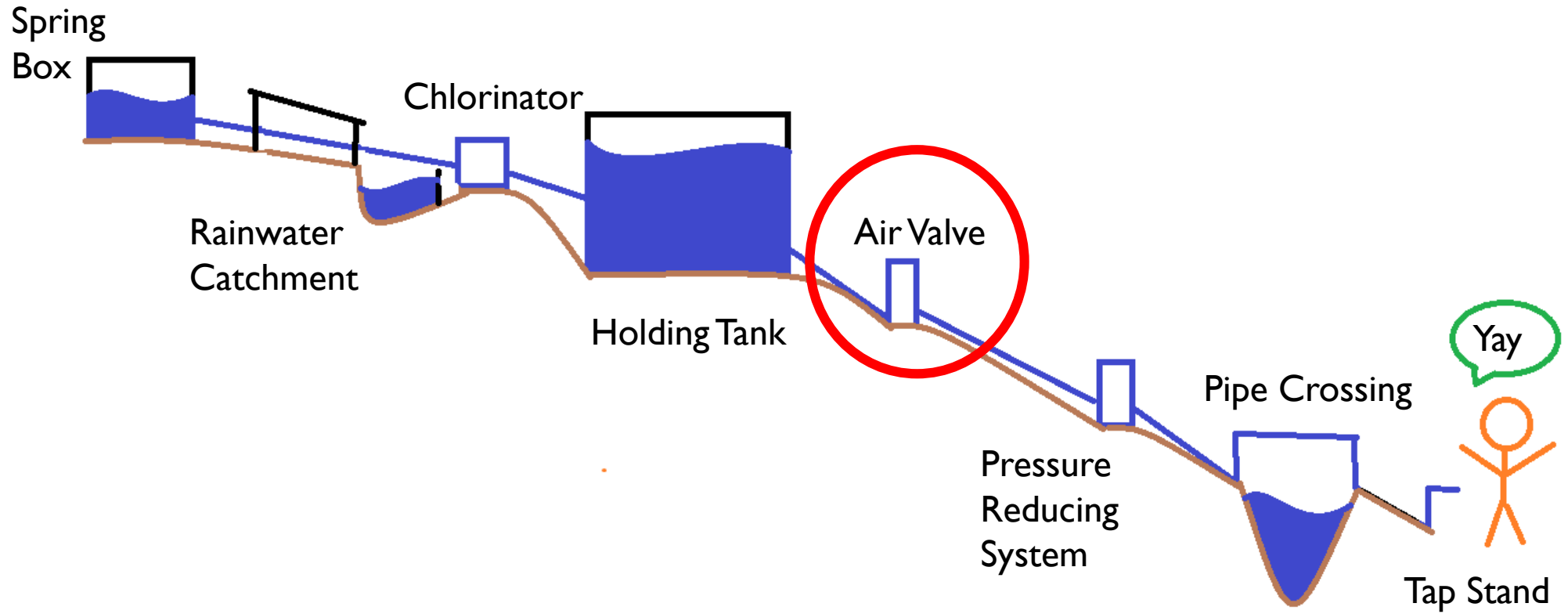

AIR VALVE

- Air blockages can occur within a gravity fed water system
 - Changes in elevation
 - High pressures
- Air valve will be placed on Louisa's branch
- The valve is closed when the system is running normally

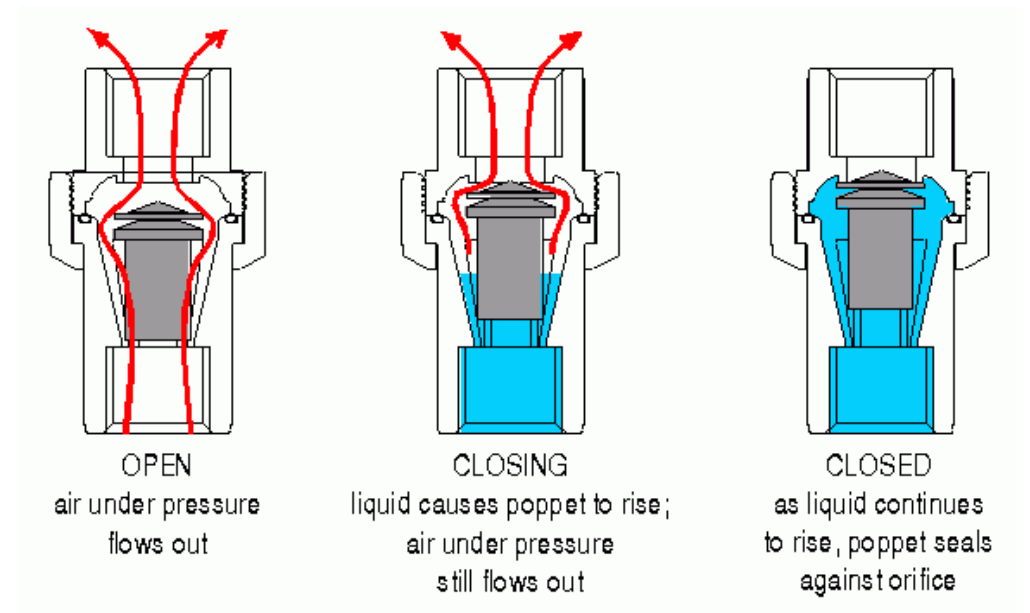

<http://plastomatic.com/arv.html>

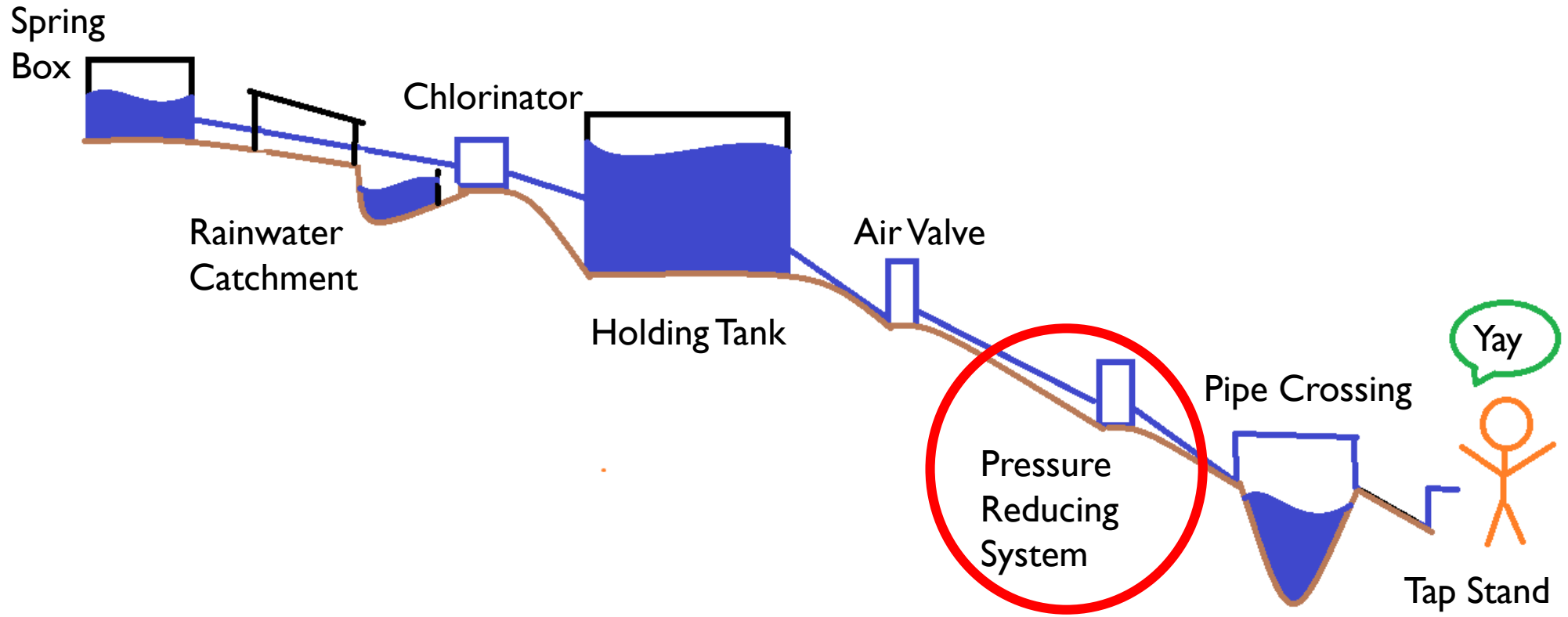

PRESSURE REDUCING VALVE/PRESSURE BREAK TANK

- High pressures occur at the lower end of the system
 - Overall elevation change of 375 feet
 - Pressures between 100 and 150 psi
- Pressure release valve
 - Reduces pressure to 25 to 75 psi
- Pressure break tank
 - Reduces pressure to atmospheric

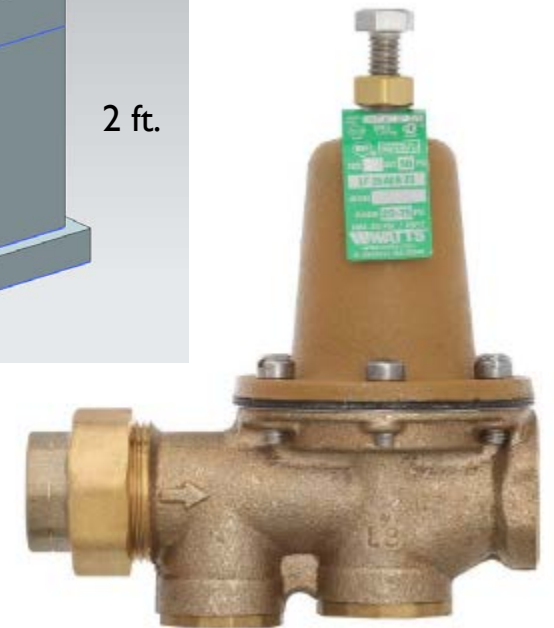
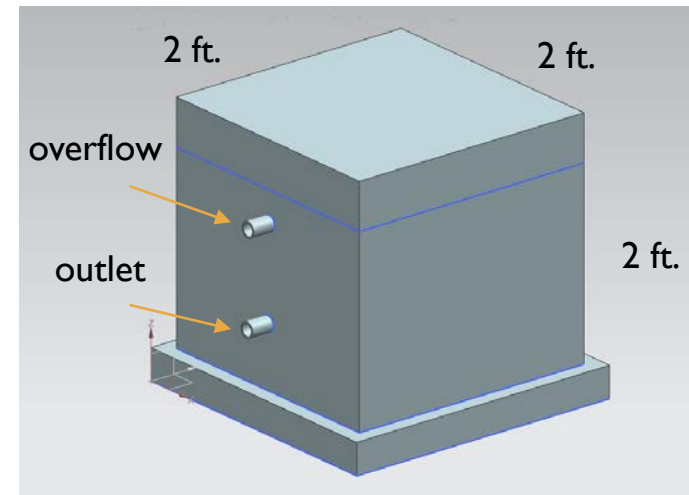

<http://www.homedepot.com/p/Watts-3-4-in-Brass-FPT-x-FPT-Pressure-Reducing-Valve-3-4-LF25AUB-Z3/202922385>

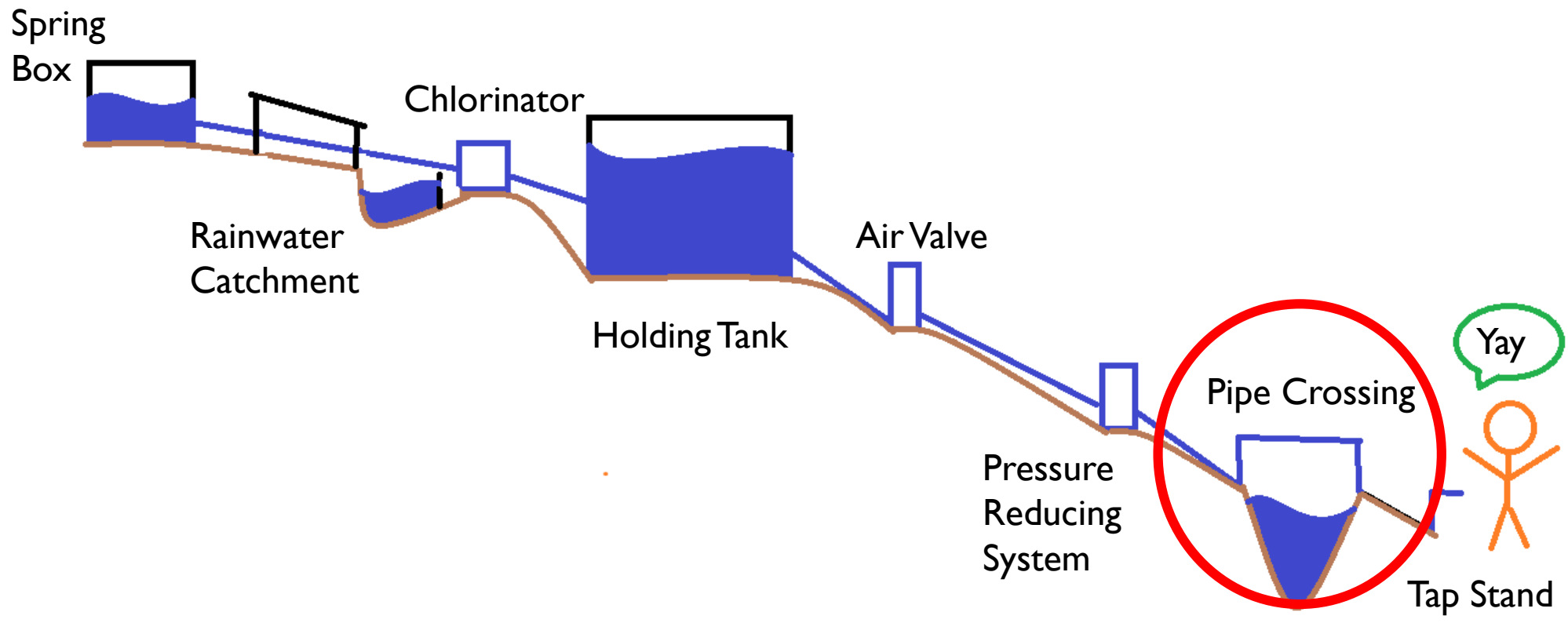

PREVIOUS PIPE CROSSING



PIPE CROSSINGS

Crossing	Length of Span (ft)	Total Tension (lbs)
1	38	395
2	83	985
3	26	250
4	25	233
5	34	322

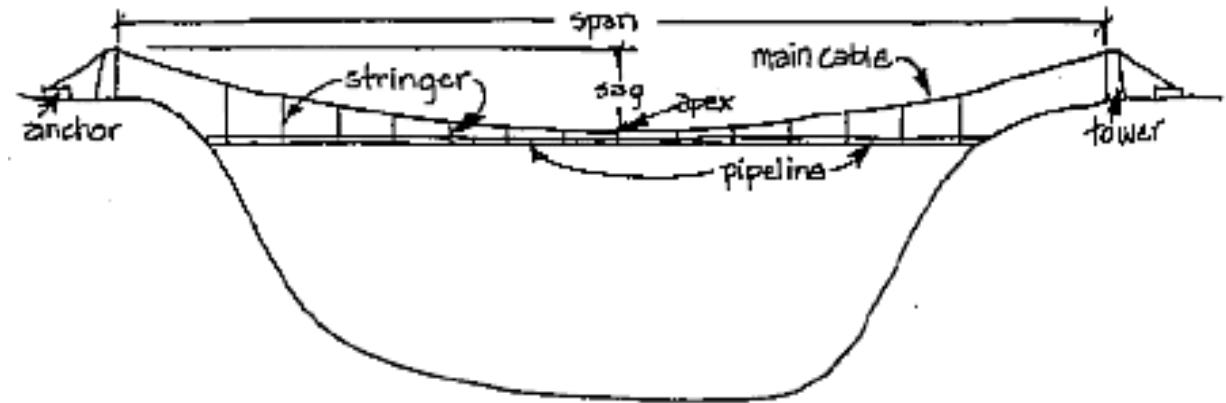

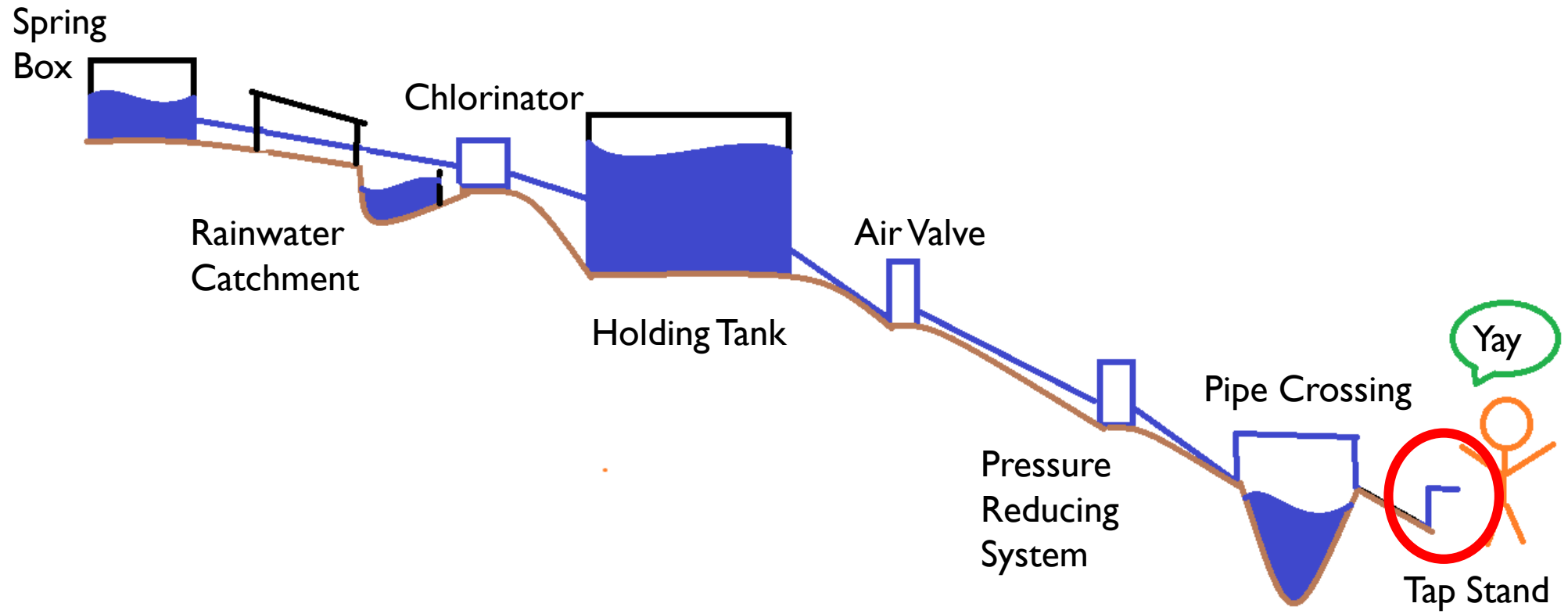

TAP STANDS AND SHUT OFF VALVES

- 13 tap stands
- 4 x 4 wooden post
- Hose clamps
- Globe valves
- 5 shut off valves
- Used for maintenance

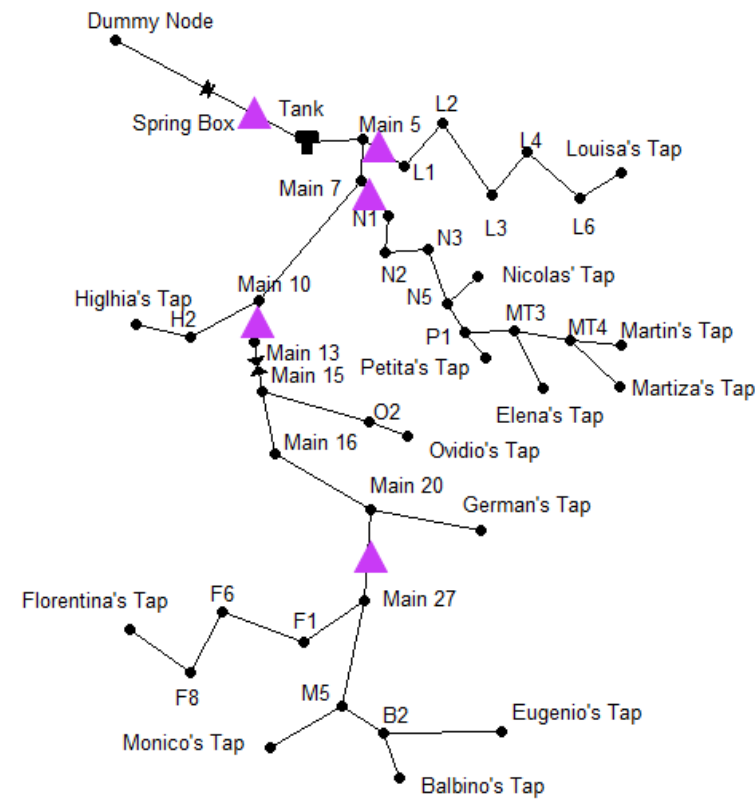

COST ESTIMATE

Item	Cost
Pipeline	\$3,500
Pressure Reducing Valve	\$180
Air Valve	\$30
Tanks	\$1,800
Pipe Crossings	\$700
Chlorinator	\$25
Rainwater Catchment	\$65
Taps	\$100
Transportation	\$400
Equipment	\$400
TOTAL	\$7,200

CONSTRUCTION SCHEDULE

- **Start date: August 1, 2017**
- **End date: November 1, 2017**
- Spring box: 7 days
- Holding tank: 7 days
- Pressure reducing valve/Pressure break tank: 1-6 days
- Pipeline: 41 days
- Laundry area: 6 days

CONCLUSION

- Next Steps:
 - Apply for grant
 - Transport materials
 - Begin construction
 - Continual maintenance
- Recommendations
 - Formal water committee
 - Monthly meetings
 - Delegate maintenance



Questions?

